



■ 主要用途

高速开关应用。

■ 极限值 (T<sub>a</sub>=25℃)

T <sub>stg</sub>	—贮存温度	.....	-55~150℃
T <sub>j</sub>	—结温	.....	150℃
V <sub>DSS</sub>	—漏极—源极电压	.....	600V
V <sub>GS</sub>	—栅极—源极电压	.....	±30V
I <sub>D</sub>	—漏极电流 (T <sub>c</sub> =25℃)	.....	7.0A
I <sub>D</sub>	—漏极电流(脉冲) (注 1)	.....	28A
P <sub>D</sub>	—耗散功率 (T <sub>c</sub> =25℃)	.....	48W

■ 外形图及引脚排列

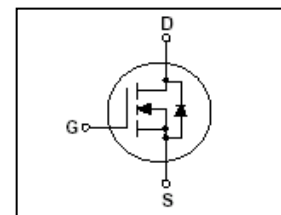
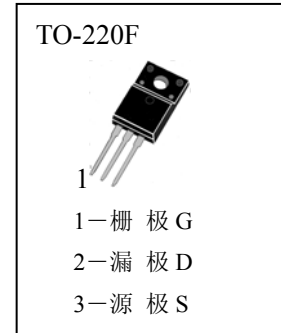

■ 电参数 (T<sub>a</sub>=25℃)

参数符号	符号说明	最小值	典型值	最大值	单位	测试条件
BV <sub>DSS</sub>	漏—源极击穿电压	600			V	I <sub>D</sub> =250 μ A, V <sub>GS</sub> =0V
I <sub>DSS</sub>	零栅压漏极电流			1	μ A	V <sub>DS</sub> =600V, V <sub>GS</sub> =0
I <sub>GSS</sub>	栅极泄漏电流			±100	nA	V <sub>GS</sub> =±30V, V <sub>DS</sub> =0V
V <sub>GS(th)</sub>	栅—源极开启电压	2.5		4.5	V	V <sub>DS</sub> = V <sub>GS</sub> , I <sub>D</sub> =250 μ A
R <sub>DS(on)</sub>	漏—源极导通电阻		0.96	1.2	Ω	V <sub>GS</sub> =10V, I <sub>D</sub> =3.5A
C <sub>iss</sub>	输入电容		970	1260	pF	V <sub>DS</sub> =25V, V <sub>GS</sub> =0, f=1MHz
C <sub>oss</sub>	输出电容		80	110	pF	
C <sub>rss</sub>	反向传输电容		17	22	pF	
t <sub>d(on)</sub>	导通延迟时间		20	40	nS	V <sub>DS</sub> =300V, I <sub>D</sub> =7.0A (峰值) R <sub>G</sub> = 25 Ω (注 2)
t <sub>r</sub>	上升时间		55	110	nS	
t <sub>d(off)</sub>	断开延迟时间		90	180	nS	
t <sub>f</sub>	下降时间		60	120	nS	
Q <sub>g</sub>	栅极总电荷		40	52	nC	V <sub>DS</sub> =480V V <sub>GS</sub> =10V I <sub>D</sub> =7.0A (注 2)
Q <sub>gs</sub>	栅极—源极电荷		6.5		nC	
Q <sub>gd</sub>	栅极—漏极电荷		16.5		nC	
I <sub>s</sub>	源极—漏极二极管正向电流			7.0	A	I <sub>S</sub> =7.0A, V <sub>GS</sub> =0
V <sub>SD</sub>	源极—漏极二极管导通电压			1.4	V	
R <sub>th(j-c)</sub>	热阻			2.6	℃/W	结到外壳

\*注 1: 漏极电流受最大结温限制。

\*注 2: 脉冲测试, 宽度 ≤300 μ S, 占空比 ≤2%



## 特性曲线

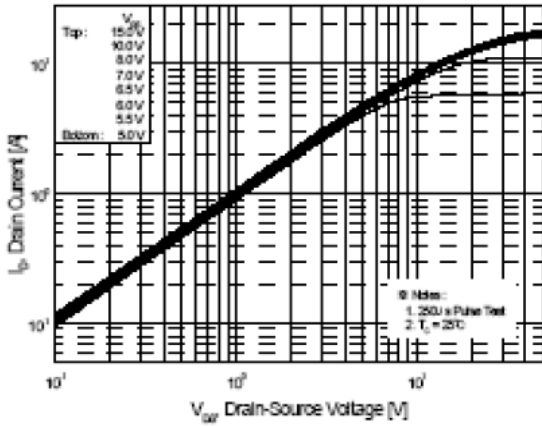

Figure 1. On Region Characteristics

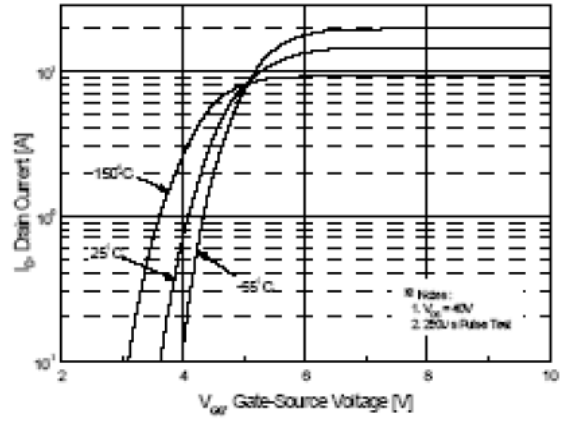

Figure 2. Transfer Characteristics

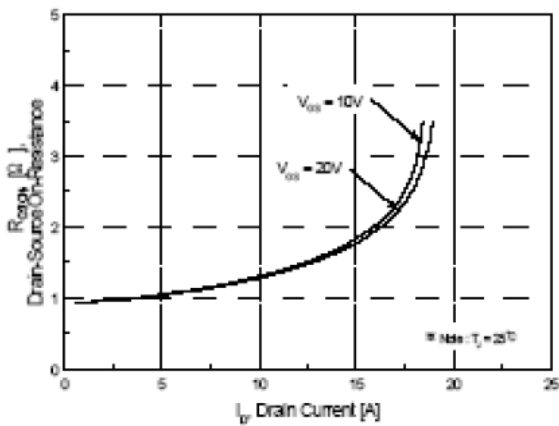

Figure 3. On Resistance Variation vs. Drain Current and Gate Voltage

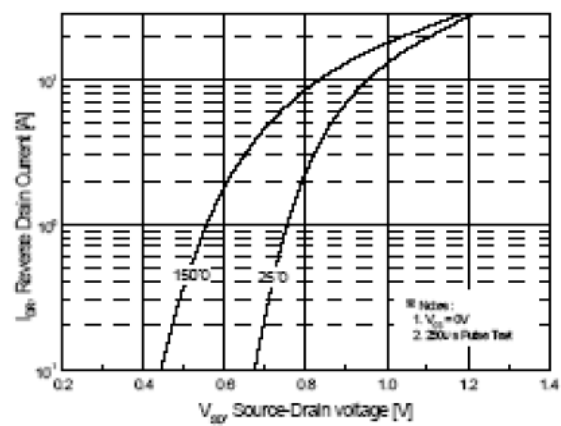

Figure 4. Body Diode Forward Voltage Variation with Source Current and Temperature

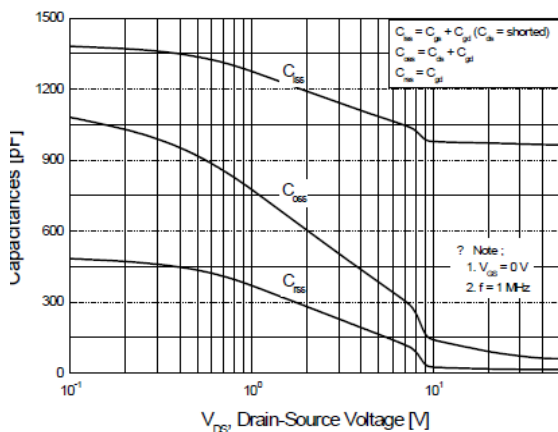

Figure 5. Capacitance Characteristics

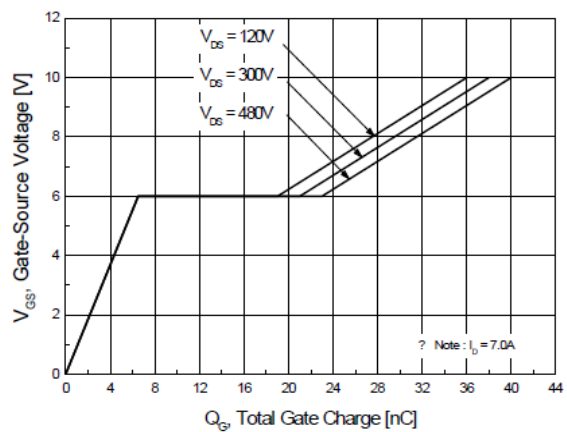

Figure 6. Gate Charge Characteristics



## ■ 特性曲线

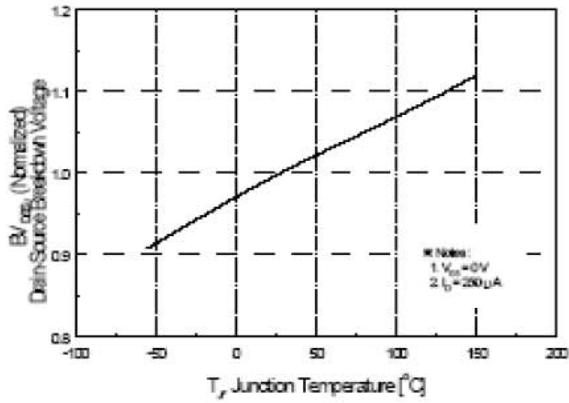

Figure 7. Breakdown Voltage Variation vs Temperature

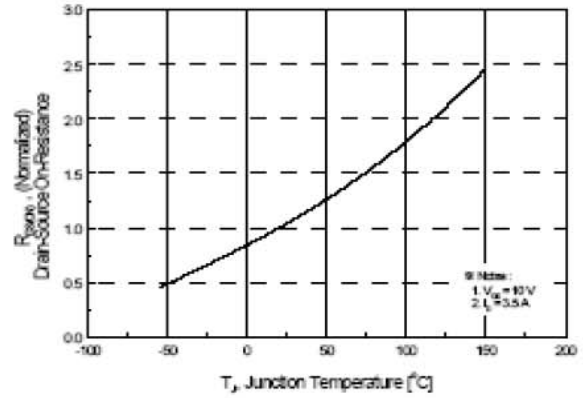

Figure 8. On-Resistance Variation vs Temperature

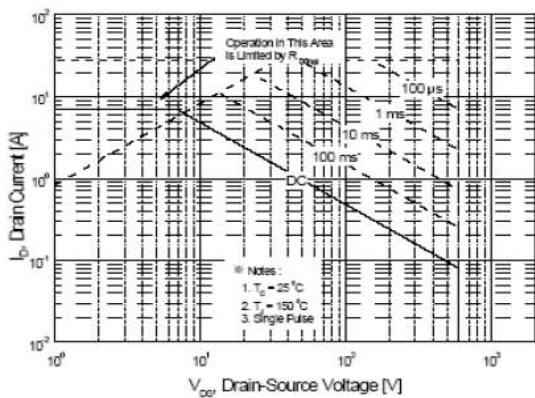

Figure 9. Maximum Safe Operating Area

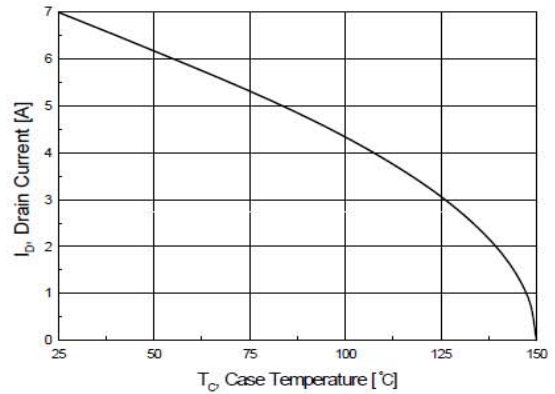

Figure 10. Maximum Drain Current vs Case Temperature

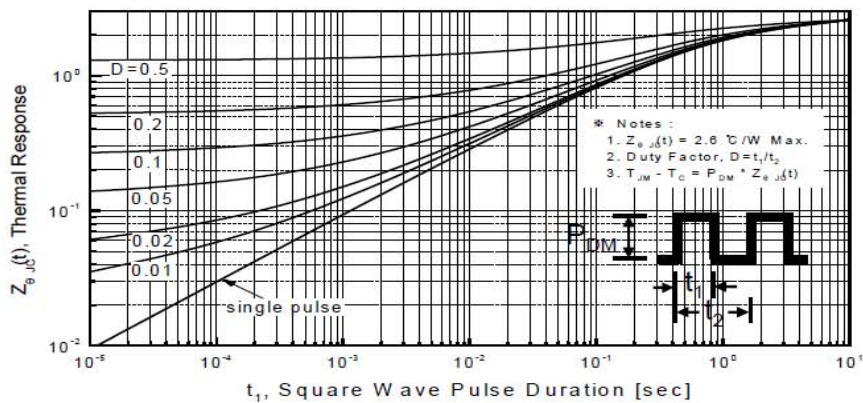

Figure 11. Transient Thermal Response Curve



■ 特性曲线

Fig 12. Gate Charge Test Circuit & Waveform

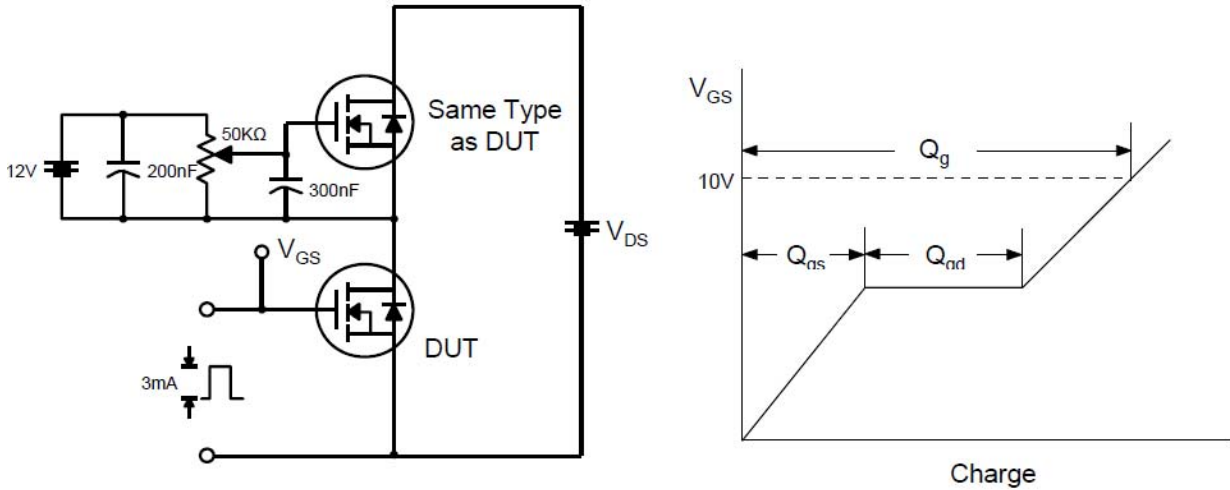

Fig 13. Resistive Switching Test Circuit & Waveforms

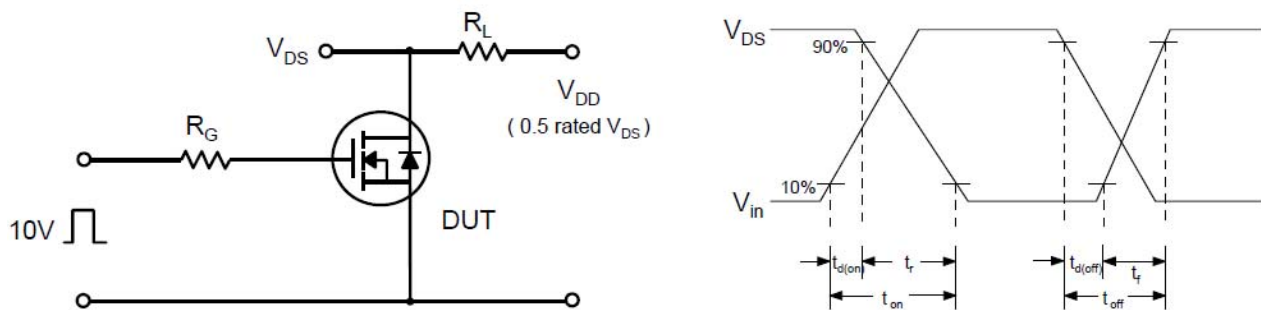
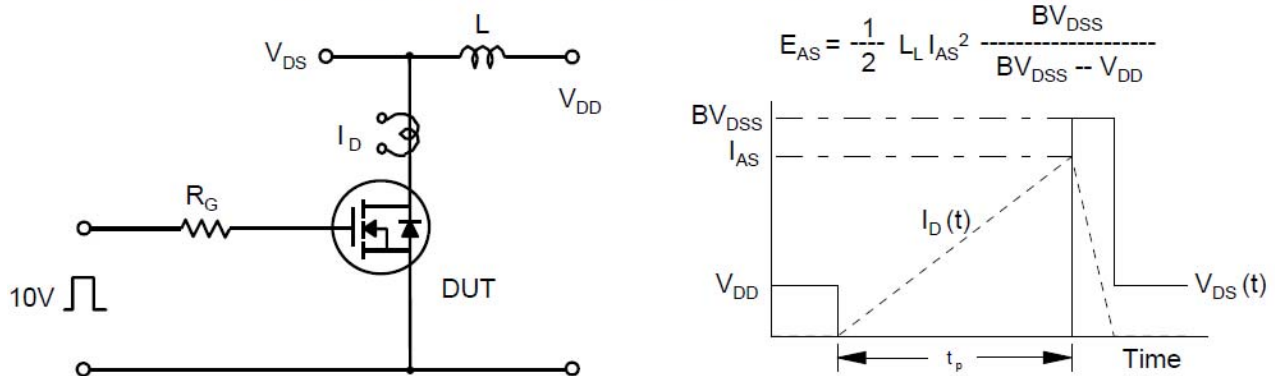

Fig 14. Unclamped Inductive Switching Test Circuit & Waveforms





## ■ 特性曲线

Fig 15. Peak Diode Recovery  $dv/dt$  Test Circuit & Waveforms

